



NEX-3/5/5C/C3 NEX-VG10/VG10E

The new functions provided by this firmware update and their respective operations are described here.

Please refer to the Instruction Manual of your camera/camcorder and LA-EA2 Mount Adaptor, and the Handbook contained on the supplied CD-ROM.

New functions

The following new functions will be provided by this firmware upgrade.

Compatibility with the LA-EA2 Mount Adaptor

Using an A-mount lens with the LA-EA2 Mount Adaptor (sold separately), you can take advantage of the phase-detection AF feature to shoot images.

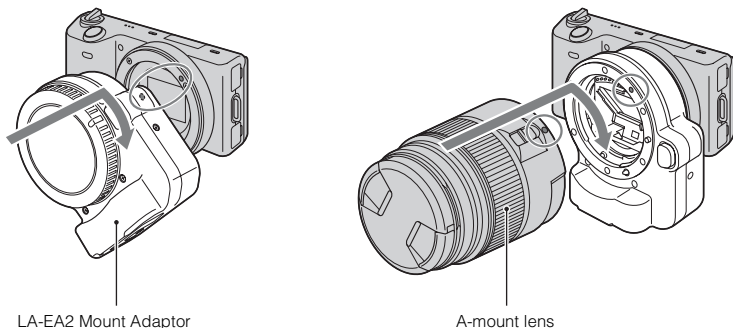

Notes

- You may not be able to use the LA-EA2 Mount Adaptor with certain lenses. You may not use autofocus with certain lenses attached via the Mount Adaptor. Consult your Sony dealer or local authorized Sony service facility for advice on compatible lenses.
- When the lens has a focusing mode switch (AF/MF), set the focusing mode with the switch of the lens. When the lens does not have the switch, set the focusing mode on the menu.
- It may take a long time or may be difficult for the camera to focus, depending on the lens used or the subject.

NEX-3/5/5C/C3:

- The following functions do not work when the LA-EA2 Mount Adaptor is attached.
 - [Smile Shutter]
 - [Face Detection]
- The noise of the camera and lens in autofocus operation may be recorded during movie recording. Using an SSM lens will reduce the noise caused by autofocus. Also, you can disable sound recording by selecting [Menu] → [Setup] → [Movie Audio Rec] → [Off].
- Aperture is set to F3.5 when you record movies with autofocus. When you are using a lens with an F3.5 or smaller F-stop, aperture is set to the maximum F-stop of the lens. When you want to set your own value for aperture to record movies, select [Aperture Priority] or [Manual Exposure] in [Shoot Mode], and select manual focusing before you start recording. The aperture setting selected at the beginning will remain in effect until you stop recording. You cannot change the aperture setting while recording a movie.

NEX-VG10/VG10E:

- If the camcorder focuses automatically during movie recording, the noise of the camcorder and lens in the autofocus operation is recorded. You can reduce the noise by connecting an external microphone with a 3.5-mm-diameter mini-plug to the microphone jack of the camcorder, and placing the microphone as far away from the camcorder as possible. If you want to eliminate the noise completely, it is recommended that you select MENU → [Setup] → [Movie Audio Rec] → [Off].

- Aperture is set to F3.5 when you record movies with autofocus. When you are using a lens with an F3.5 or smaller F-stop, aperture is set to the maximum F-stop of the lens. When you want to set your own value for aperture to record movies, select [Aperture Priority] or [Manual Exposure] in [Shoot Mode], and select manual focusing. If you change the aperture while recording a movie, the noise may be heard or the screen may become brighter while the camcorder is processing the adjustment.

New functions provided in the menu

The following functions will be added to the menu by this firmware upgrade.



Menu	New items	Functions
Camera	Autofocus Area	Allows you to set a position for phase-detection AF, when the LA-EA2 Mount Adaptor is attached.
Setup	AF micro adjustment (AF Micro Adj./amount/Clear)	Allows you to adjust the autofocused position finely, when the LA-EA2 Mount Adaptor is attached.
	Peaking (Peaking Level/Peaking Color) (NEX-VG10/VG10E only)	Enhances the outline of in-focus ranges with a specific color in manual focus.

- The peaking function is provided for NEX-3/5/5C/C3 in the previous firmware version. Refer to the corresponding Instruction Manual on the operation and setting.
NEX-3/5/5C: Instruction Manual of Ver. 04
NEX-C3: Ver. 01 (Instruction Manual supplied with the camera)

Autofocus Area

Allows you to set a position for phase-detection AF, when using an A-mount lens with the LA-EA2 Mount Adaptor (sold separately). You can only set the position for phase-detection AF when an A-mount lens with the LA-EA2 Mount Adaptor is attached.

1 [Menu] → [Camera] → [Autofocus Area] → desired mode.

 (Wide)	The camera determines which of the 15 AF areas is used for focusing.
 (Spot)	The camera uses the AF area located in the center area exclusively.
 (Local)	Allows you to choose the area for which you want to activate the focus from among 15 AF areas with the control wheel (NEX-3/5/5C/C3) or the ▲/▼/◀/▶ buttons (NEX-VG10/VG10E).

AF Micro Adj./amount/Clear

Allows you to adjust and register an autofocused position for each lens, when using an A-mount lens with the LA-EA2 Mount Adaptor (sold separately).

- 1 [Menu] → [Setup] → [AF Micro Adj.] → [On].
- 2 [Menu] → [Setup] → [amount] → desired value → OK.

AF Micro Adj.	Sets whether or not to use the [AF Micro Adj.] function. Select [On] to use it. (The default setting is [Off].)
amount	Allows you to select an optimum value between -20 and +20. Selecting a larger value shifts the autofocused position away from the camera. Selecting a smaller value shifts the autofocused position closer to the camera.
Clear	Clears the value you set.

Notes

- It is recommended that you adjust the position under actual shooting conditions.
- When you attach a lens for which you have already registered a value, the registered value appears on the screen. [±0] appears for lens for which a value has yet to be registered.
- If [-] appears, more than 30 lenses have been registered. If you want to register another lens, you must first clear a value. Attach a lens of the value to be cleared and select [±0]. If you want to clear all registered values, select [Clear].
- Use [AF Micro Adj.] with Sony, Minolta, and Konika-Minolta lenses only. If you use [AF Micro Adj.] with other brands of lenses, the registered value may be affected.
- You cannot set [AF Micro Adj.] individually for a Sony, Minolta, and Konika-Minolta lens of the same specification.

Peaking Level (NEX-VG10/VG10E only)

Enhances the outline of in-focus ranges with a specific color in manual focus. This function allows you to confirm the focus easily.

1 MENU → [Setup] → [Peaking Level] → desired setting.

	High	Sets the peaking level to high.
	Mid	Sets the peaking level to middle.
	Low	Sets the peaking level to low.
✓	Off	Does not use the peaking function.

Notes

- Since the camcorder judges that sharp areas are in focus, the peaking level is different, depending on the subject, shooting situation, or on the lens used.
- The outline of in-focus ranges is not enhanced when the camcorder is connected using an HDMI cable.

Peaking Color (NEX-VG10/VG10E only)

Sets the color used for the peaking function in manual focus.

1 MENU → [Setup] → [Peaking Color] → desired setting.

✓	White	Enhances outlines in white.
	Red	Enhances outlines in red.
	Yellow	Enhances outlines in yellow.

Note

- This item cannot be set when [Peaking Level] is set to [Off].